

Shop Press C FRAME

25 Tons
Press

SHOP EQUIPMENT



- Can be bench mounted or on optional pedestal base.
- Bench mount requires less than 1.4 sq. m. of space; on optional pedestal, only 0,4 sq.m. of floor space is needed.
- "Open Throat" design makes loading and unloading of work easy.
- Cylinder head adjusts to three convenient working positions, providing up to 514 mm of "daylight."
- Hydraulic cylinder delivers a 159 mm stroke, is driven by a P59 two-speed hand pump.
- **Pedestal Base No. 60846** – Provides a stable base for SPM256C. Includes a bracket for mounting the pump on the side of pedestal press. Wt., 34,5 kg.

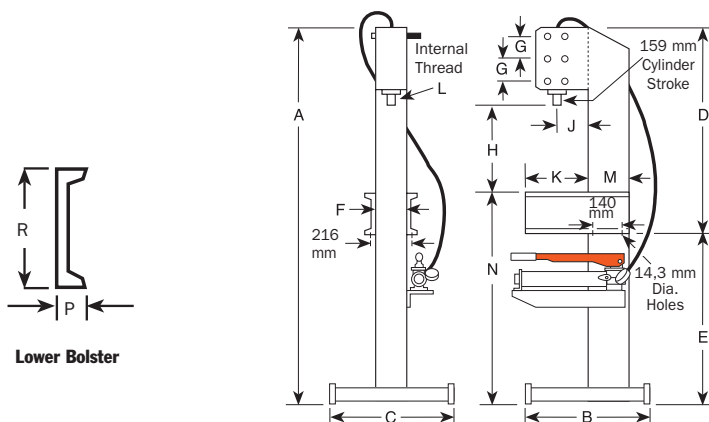

DIMENSIONS

A	B	C	D	E	F	G	H (Cyl. Retracted)	J	K	L	M	N	P	R	Floor Space
(mm)	(mm)	(mm)	(mm)	(mm)	(mm)	(mm)	(mm)	(mm)	(mm)	(mm)	(mm)	(mm)	(mm)	(mm)	(mm)
1.972	622	610	1.057	914	152	127	260, 387, 514	165	318	1½ – 16	203	1.092	51	178	610 x 622

CE

ORDERING INFORMATION

Capacity (tons)	Type Cyl. Used	Stroke (mm)	Cyl. Model	Order No.	Speed** Advance	Pressing	Type Pump	Pump Model	Prod.Wt. (kg)
25	Single-Acting	159	C256C	SPM256C*	3,3 mm/ stroke	0,8 mm/ stroke	Hand	P59	108

* SPM256C does not include No. 60846 pedestal base.

** Typical performance based on pump specifications. Actual speeds may vary with operating conditions.